

RAPID Column Formwork

Assembly Instructions for Standard Configuration

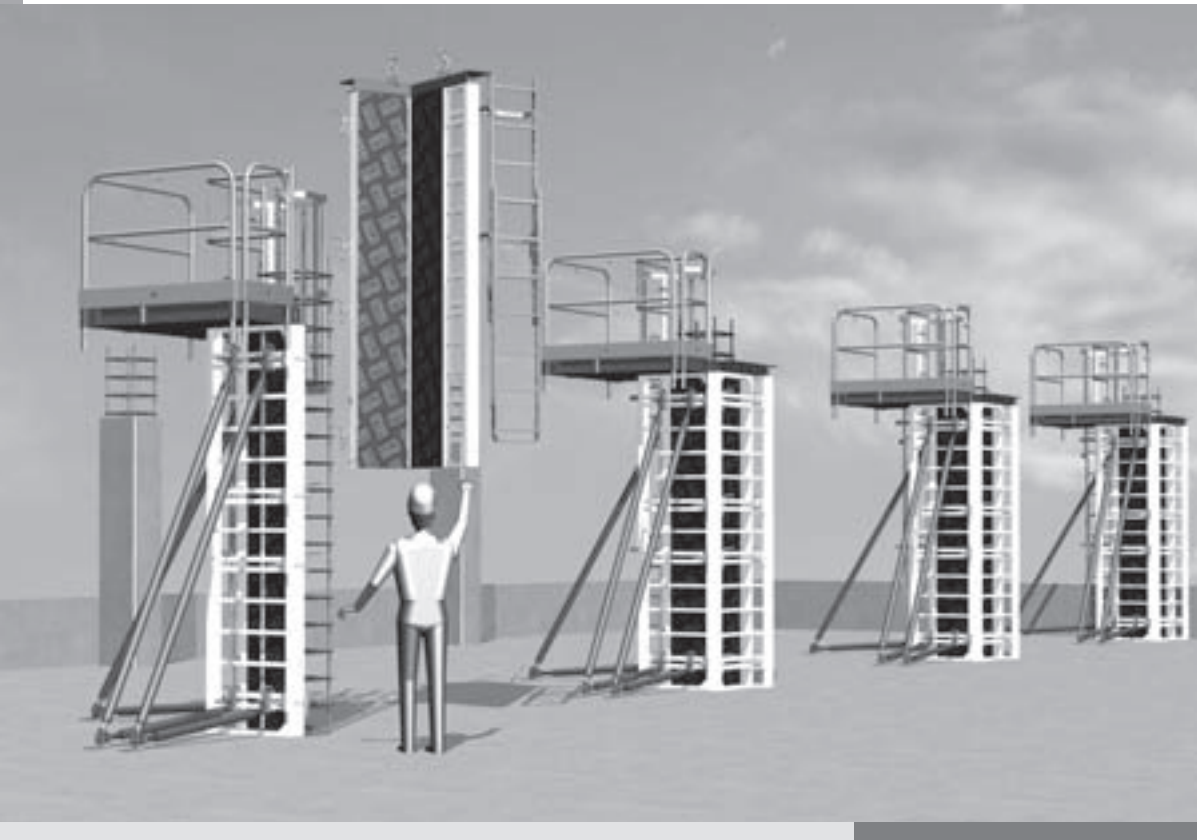

Content

Introduction		
	Overview, Main Components	1
	Standard Configuration	2
	Intended Use	2
	Safety Instructions	3
	General	3
A Assembly and Dismantling		
A1	Cleaning	
	Cleaning	4
A2	Assembly	
	Formlining Installation with Chamfer Strip	5
	Push-Pull Props	8
	Concreting Platform	9
	Access Ladder	10
	Parts list for Access Ladders	11
A3	Shuttering	
	Placing of Formwork	12
	Installation of Reinforcement	13
	Closing of Formwork	13
A4	Striking and Moving	
	Striking and Moving	14
A5	Oversized Column Cross-Sections	
	Oversized Column Cross-Sections	15
A6	Height Adjustment	
	Height Adjustment up to 8.10 m	16
Components		
	Components	18

Key



Safety Instructions



Note



Visual Check



Tip

Introduction

Overview, Main Components

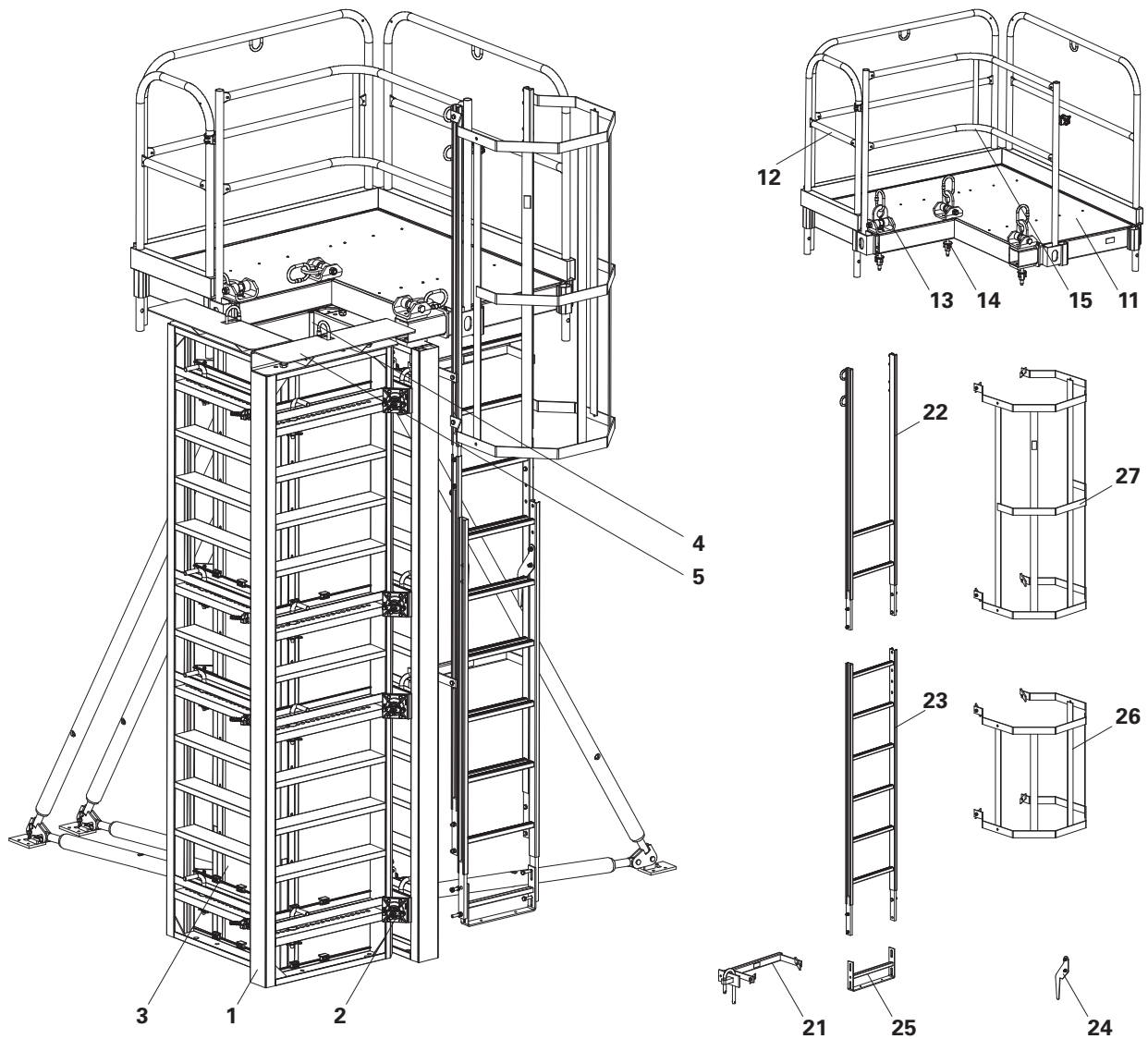

RAPID Column

- 1 Column Frame
- 2 Corner Profile with Column Tie Bolts and Bolts
- 3 Formlining
- 4 Chamfer Strip
- 5 Crane Suspension

Concreting Platform, complete

- 11 Concreting Landing
- 12 Guardrail 134 or 52
- 13 Crane Eye
- 14 Cam Nut DW 15
- 15 Front Guardrail Landing 86/86

Access Ladder

- 21 Ladder Connector RAPID
- 22 End Ladder 180/2
- 23 Ladder 180/6
- 24 Ladder Hook
- 25 Ladder Base
- 26 Ladder Safety Cage 75
- 27 Ladder Safety Cage 150

Introduction

Standard Configuration

General

PERI RAPID is the column formwork for joint-free architectural concrete. The column frame is made of aluminium and powder-coated to ensure easy and simple cleaning. The cut-to-size formlining sheets are firmly connected to the frame by means of clamping profiles. As a result, no screw or nail impressions are visible on the concrete surface. With extended column frames, the plywood formlining can be continuously fitted over the joints of the column frames. Sharp-edged column cross-sections can be realised through the use of chamfer strips. Through the formwork element arrangement, which is based on the windmill vane principle, both square and rectangular column cross-sections can be continuously formed.

System Dimensions

Formwork height:

Maximum 8.10 m, extendable in 30 cm increments.

Column cross-sections:

Continuously adjustable square or rectangular cross-sections of up to 60 x 60 cm. With sharp-edged designs, a maximum of 58 x 58 cm.

Oversized cross-sections from 85 x 85 cm to 135 x 135 cm with additional ties through the concrete.

Thickness of the plywood formlining:

21 mm for columns with chamfer strips, 30 mm for sharp-edged columns.

Technical Data

Permissible fresh concrete pressure 120 kN/m².

Intended Use

1. PERI products have been designed as technical work equipment for exclusive use in the industrial and commercial sectors by suitably trained personnel.
2. These assembly instructions serve as the basis for the project-related risk assessment and the instructions for the provision and use of the system by the contractor (user). However, they do not replace these.
3. Only PERI original components may be used. The use of other products and spare parts represents a misapplication with associated safety risks.

4. The components are to be inspected before each use to ensure that they are in perfect condition and function correctly.
5. Changes to PERI components are not permitted and represent a misapplication with associated safety risks.
6. Safety instructions and permissible loads must be observed at all times.
7. Components provided by the contractor must conform with the characteristics required in these assembly instructions as well as all valid construction guidelines and standards.

In particular, the following apply if nothing else is specified:

- timber components: Strength Class C24 for Solid Wood EN 338.
 - scaffold tubes: galvanised steel tubing with minimum dimensions Ø 48.3 x 3.2 mm according to EN 12811-1:2003 4.2.1.2.
 - scaffold tube couplings according to EN 74.
8. Deviations from the standard configuration may only be carried out after a separate risk assessment has been completed by the contractor (user). On this basis, appropriate measures for the working safety and stability are to be implemented.

Introduction

Safety Instructions

General

1. Deviations from the standard configuration and/or intended use present a potential safety risk.
2. All country-specific laws, standards and other safety regulations are to be taken into account whenever our products are used.
3. During unfavourable weather conditions, suitable precautions and measures are to be taken in order to ensure both working safety and stability.
4. The contractor (user) must ensure the stability throughout all phases of construction. He must ensure and verify that all loads which occur can be safely transferred.
5. The contractor (user) has to provide safe working areas for site personnel which are to be reached through the provision of safe access means. Areas of risk must be cordoned off and clearly marked. Hatches and openings on accessible working areas must be kept closed during working operations.
6. For better comprehensibility, detailed drawings are partly incomplete. The safety installations which have possibly not been featured in these detailed drawings must nevertheless be available.

Storage and Transportation

1. Do not drop the components.
2. Store and transport components ensuring that no unintentional change in their position is possible. Detach lifting gear from the lowered units only if these are in a stable position and no unintentional change is possible.
3. When moving the components, make sure they are lifted and set down so that any unintentional tipping over, falling apart, sliding or rolling away are avoided.
4. Use only suitable load-carrying equipment to move the components as well as the designated load-bearing points.
5. During the lifting and moving procedure, ensure all loose parts are removed or secured.
6. During the moving procedure, always use a guide rope.
7. Move components on clean, flat and sufficiently load-bearing surfaces only.

System-specific

1. Retract components only when the concrete has sufficiently hardened and the person in charge has given the go-ahead for striking to take place.
2. Anchoring is to take place only if the anchorage has sufficient concrete strength.
3. Only use designated PERI lifting accessories.
4. During striking, do not tear off the formwork panels with the crane.
5. If a storm warning is given, additional push-pull props are to be attached or other bracing measures are to be carried out along with implementing the details contained in the PERI design tables.

General

Additional PERI product information

- RAPID column formwork brochure
- PERI design tables

The assemblies shown in these PERI assembly instructions are only examples which feature only one component size. They apply accordingly for all component sizes contained in the standard configuration.

A1 Cleaning

Cleaning

In order to maintain the value and operational readiness of the RAPID column formwork over a long period of time, the formwork should be carefully handled at all times.

Maintenance tips

1. Concrete vibrator with rubber end cap reduces the risk of damage to the formlining.
2. Spray the components with PERI Bio Clean before every use and clean the rear of the formwork with water immediately after concreting.
3. Spray moving parts, if required, with PERI Bio Clean.



Due to the powder coating, cleaning requirements are kept to a minimum.



A2 Assembly

Formlining Installation with Chamfer Strip

Plywood formlining cut-to-size

Plywood formlining: 21 mm
(Fig. A2.01)



Horizontal formlining joints must be positioned on the frame cross struts.

1. Lay column frame on the assembly trestles.
(Fig. A2.02)

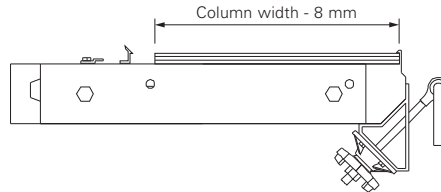

Plywood formlining width - example:

Column width 55 cm	550 mm
- reduction in size	8 mm
Actual cut	542 mm

Fig. A2.01

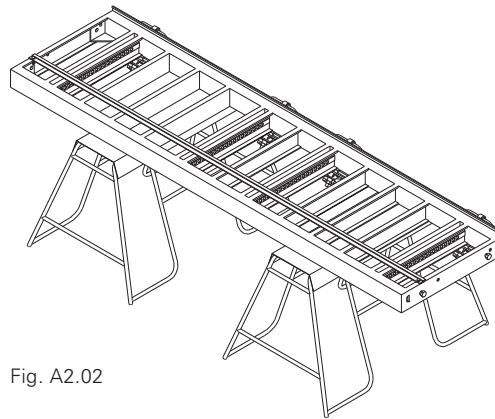

Fig. A2.02

2. Bolt column frames together according to the required height of the column (SW 30).
(Fig. A2.03)

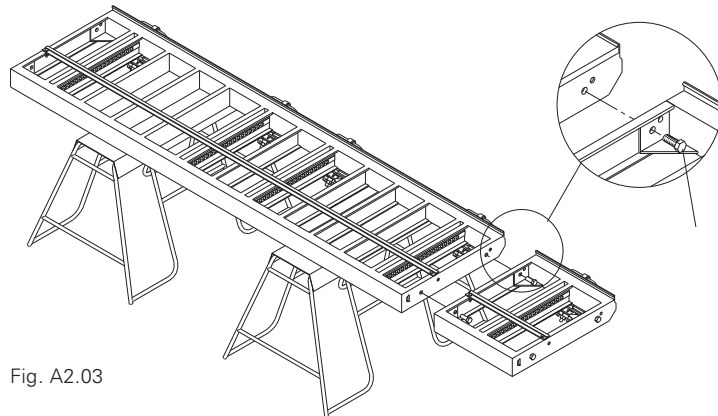

Fig. A2.03

3. Install plywood formlining and slide into the retainers.
(Fig. A2.04)

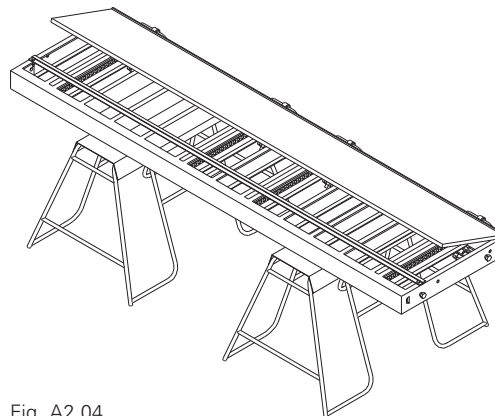

Fig. A2.04

A2 Assembly

4. Fit chamfer strip and position on plywood formlining. (Fig. A2.05)
5. Slide clamping profile over chamfer strip. (Fig. A2.05a)
6. Fix with screw clamps. (Fig. A2.06)
7. Clamp plywood formlining and chamfer strip with clamping profile. (Socket Wrench SW 17)
8. Remove screw clamps.
9. Secure plywood formlining against slipping with nails. For this, use holes in the support profiles. (Fig. A2.05a)

Formlining for other column frames is installed in the same manner.

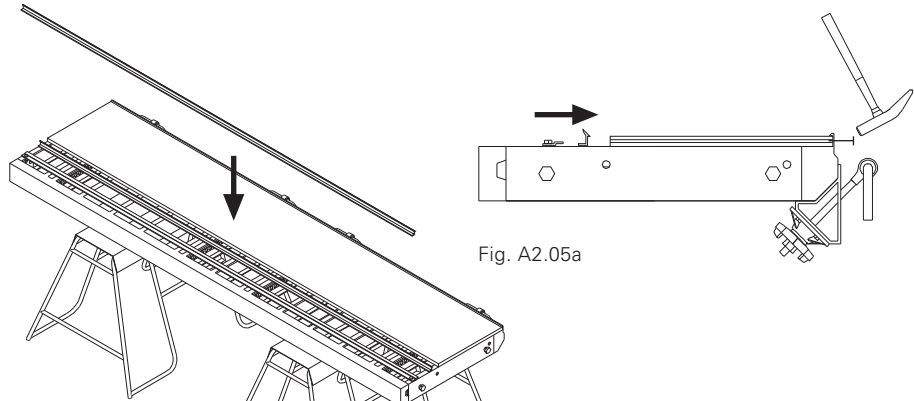

Fig. A2.05

Fig. A2.05a

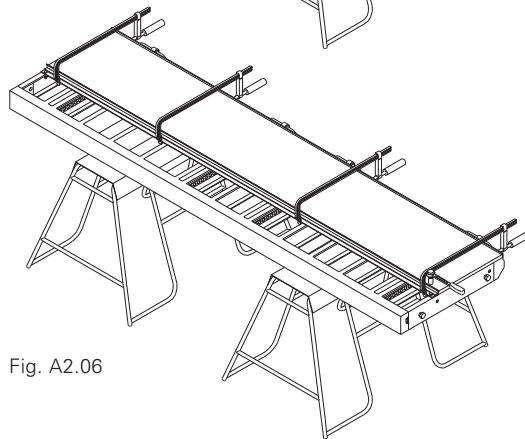

Fig. A2.06

Plywood formlining - overhang

- below max. 4 cm
- above max. 20 cm with crane suspension. (Fig. A2.07)

Sharp-edged execution

Max. cross-section dimensions 58 x 58 cm.

30 mm plywood formlining which is milled accordingly is required when forming without chamfer strips. (Fig. A2.08)

This is held in position by means of clamping profiles and support profiles. (Fig. A2.08a)
Secure formlining against slipping.

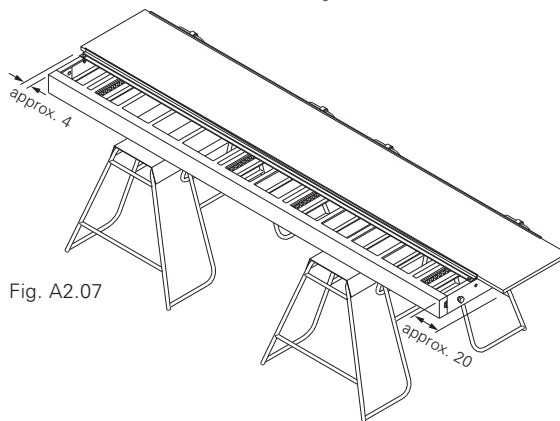

Fig. A2.07

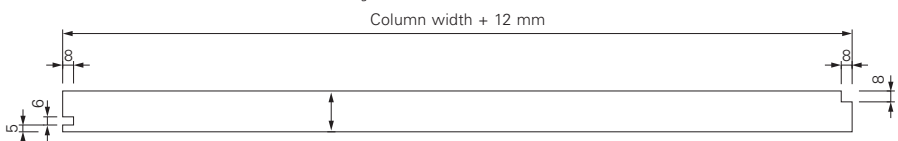

Fig. A2.08

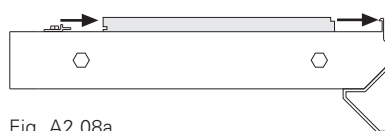

Fig. A2.08a

Plywood formlining width - example:

Column width 55 cm	550 mm
+ site measurement	12 mm
Actual cut	562 mm

Installing the formwork halves

1. Place second pre-assembled column frame on the first column frame. (Fig. A2.09)
2. Insert tie yoke through the corner connection.
3. Insert bolts in the perforated strip.
4. Tighten with nuts. (Fig. A2.09a)
5. Install the second formwork half in the same way.

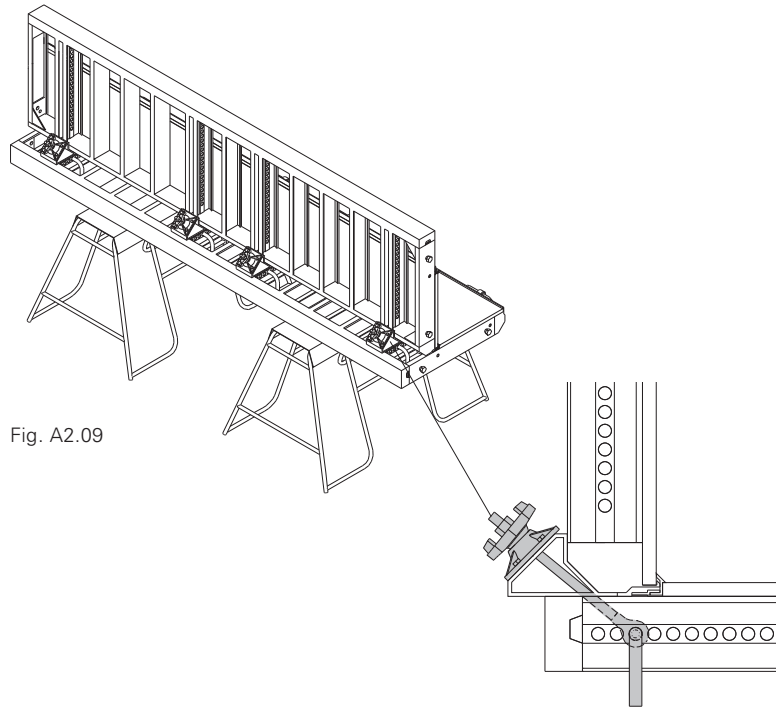

Fig. A2.09

Fig. A2.09a

Crane Suspension

One lifting unit per column frame; however, not with concreting platforms. Here, the lifting unit is fixed to the concreting platform.

1. Loosen bolt SW 30 in the column frame.
2. Place lifting unit on the frame and attach using bolts SW 30. (Fig. A2.10 + A2.10a)

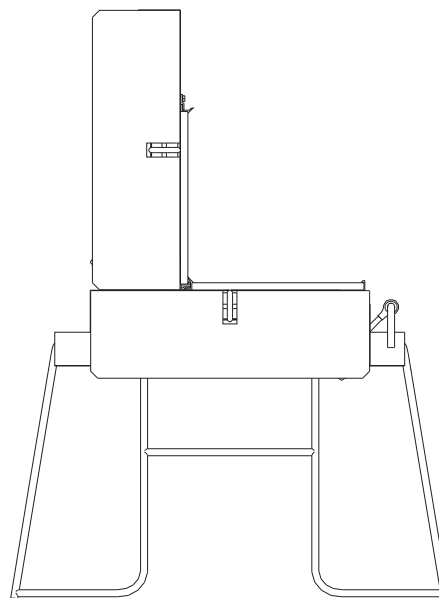

Fig. A2.10

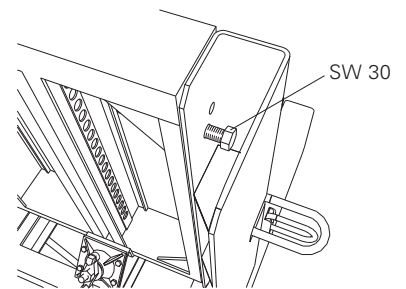

Fig. A2.10a

A2 Assembly

Push-Pull Props



Mount 3 push-pull props to ensure stability!

Mount three brace connectors to one formwork half.
(Fig. A2.11)

1. Remove bolts.
2. Place brace connector on perforated strip.
3. Insert tie yoke in the perforated strip and fix with bolt.
(Fig. A2.11a)
4. Fix push-pull prop and kicker with bolts and cotter pins.
(Fig. A2.12)

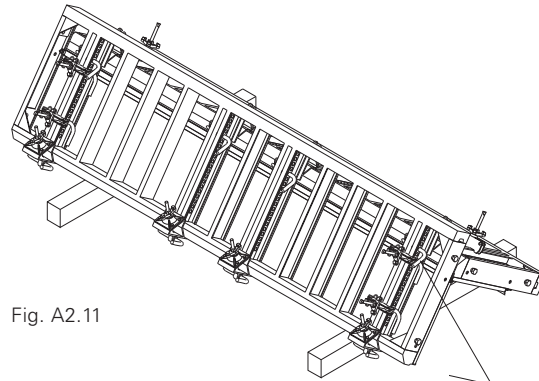

Fig. A2.11

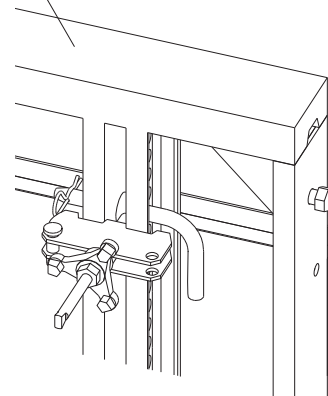

Fig. A2.11a

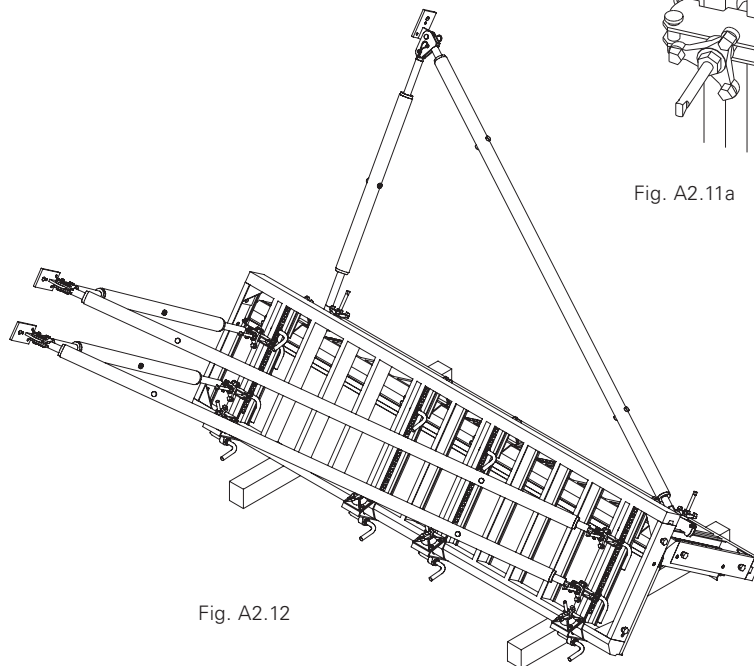

Fig. A2.12

A2 Assembly

Concreting Platform

Assembly on the horizontally-positioned formwork half.

1. Remove cam nuts from the crane eyes.
 2. Remove bolts SW 30 from the column elements.
 3. Place the platform in an upright position by hand on the formwork half.
 4. Insert crane eye bolt through drilled hole a of the column panel and open cam nuts.
 5. Proceed in the same way with drilled hole b.
 6. Align telescopic girder to drilled hole c and mount third crane eye.
- (Fig. A2.13)
7. Insert guardrail.
- (Fig. A2.14)

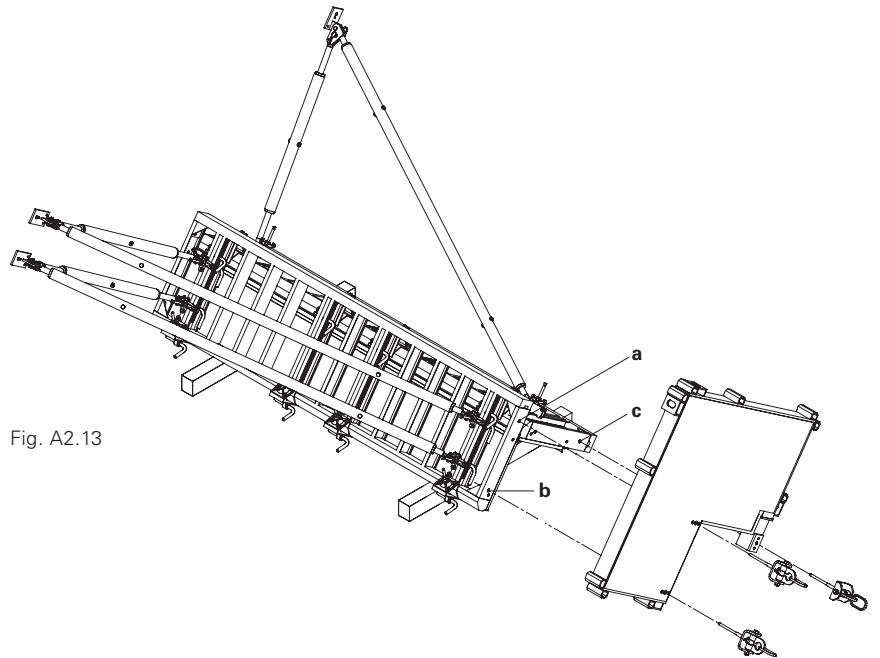

Fig. A2.13

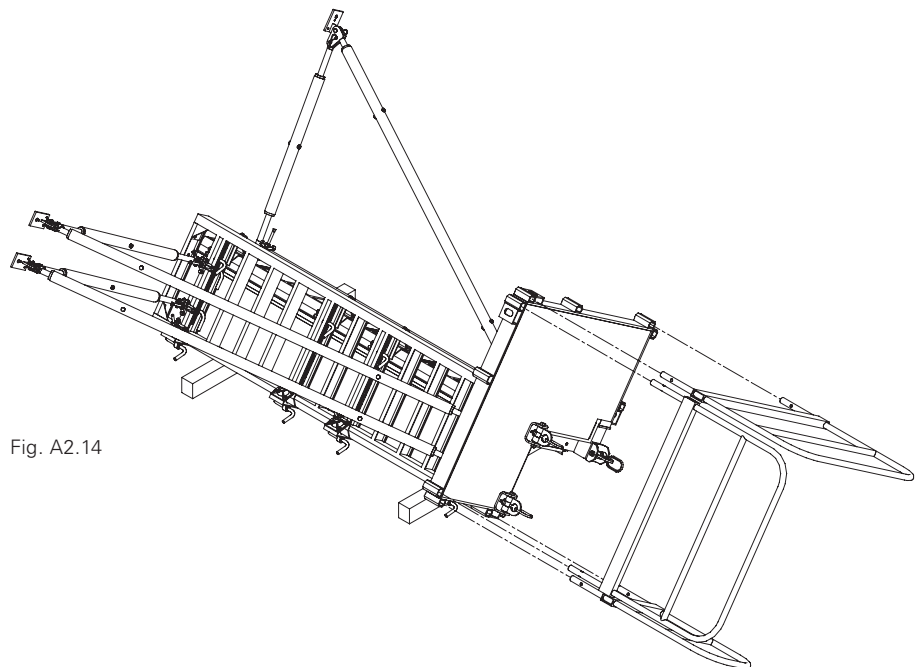

Fig. A2.14

A2 Assembly

Access Ladder

Assembly on the horizontally-positioned formwork half.

1. Place ladder connector on the frame and fix by means of bolts in the perforated strip. (Fig. A2.15)
2. Pre-assemble ladder:
 - Connect End Ladder 180/2 with Ladder 180/6, SW 19. Depending on the height, mount additional Ladders 180/6.
 - Mount ladder base and ladder to bottom ladder, SW 19. (Fig. A2.16)
3. Attach the pre-assembled ladder to the ladder connectors by means of the clamping plates, SW 19.
4. Mount Ladder Safety Cage 150 or 75 with clamping plates according to plan. Depending on the situation, mount with overlapping ladder joints. (Fig. A2.17) Clear spacing between the ladder safety cages ≤ 30 cm. Visual check of the clamping plates. The contact surface must rest against the ladder profile.
5. For high columns: Ladder access is also installed for closing the formwork on the second formwork half. It is without any access possibility!

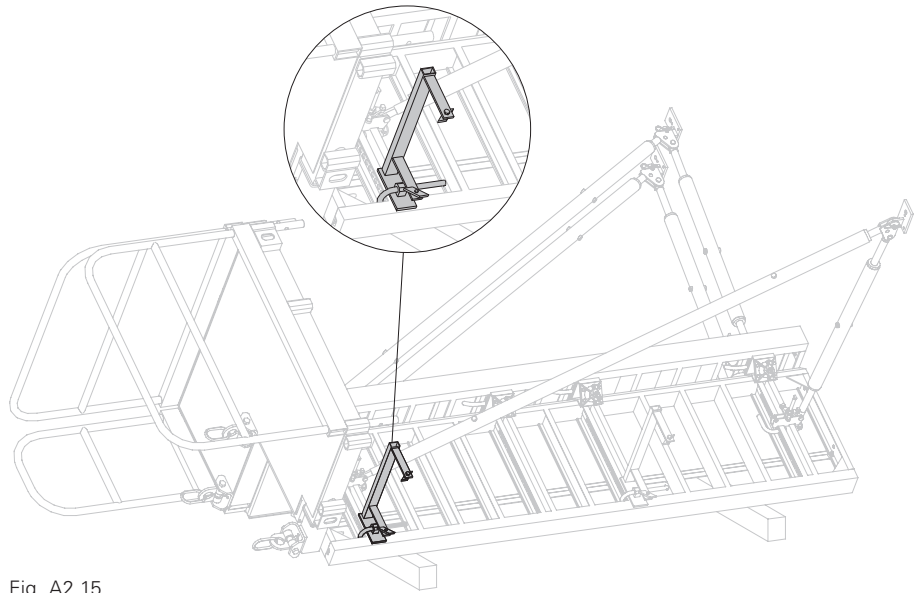

Fig. A2.15

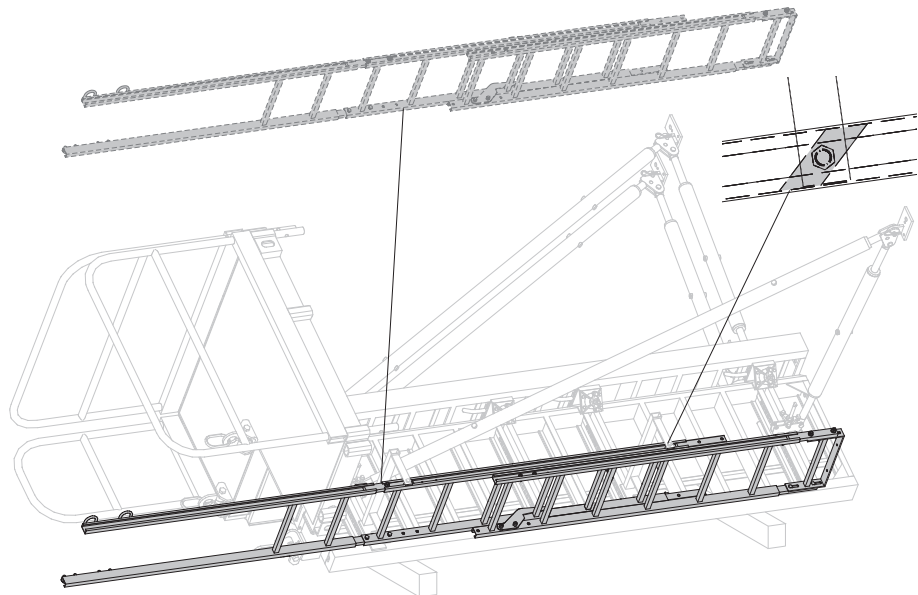

Fig. A2.16

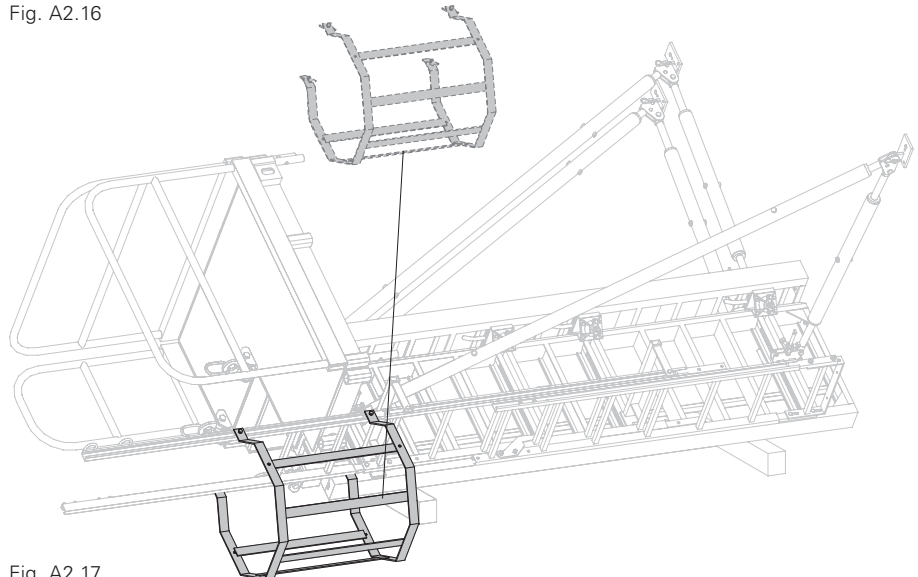

Fig. A2.17

A2 Assembly

Parts list for Access Ladders



For higher columns, two access ladders are mounted!

Ladder Access A:
with access to the concreting platform.

Ladder Access B:
without exit possibility, only for bracing the column formwork.



For heights of more than 7.80 m, we recommend the use of two concreting platforms.

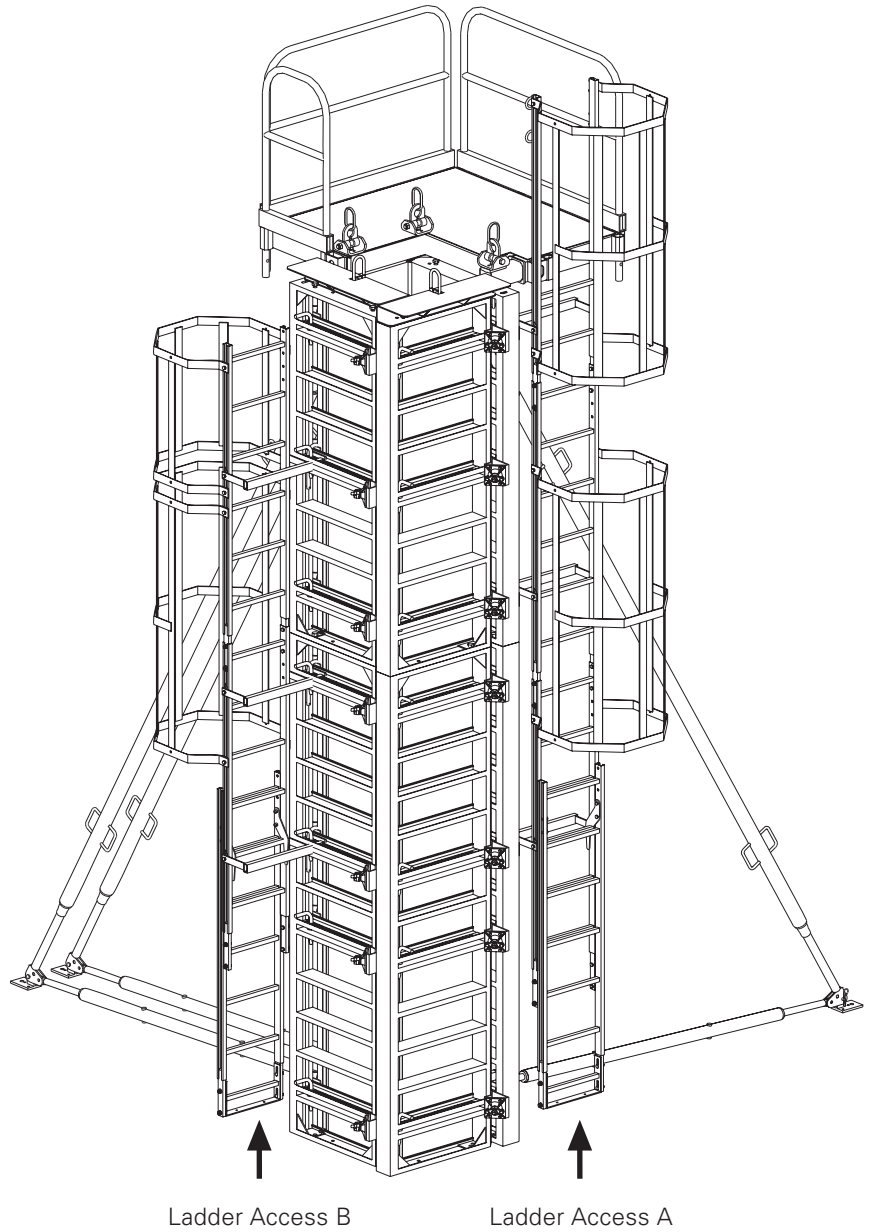

Item no.	Description	2.70 – 3.60 m		3.90 – 4.20 m		4.50 – 5.70 m		6.00 – 7.50 m		7.80 – 9.30 m		9.60 – 10.80 m	
		A	B	A	B	A	B	A	B	A	B	A	B
037400	Concreting Platform, complete	1	0	1	0	1	0	1	0	1	0	1	0
051410	Ladder 180/6	2	2	2	2	3	3	4	4	5	5	6	6
103724	End Ladder 180/2	1	0	1	0	1	0	1	0	1	0	1	0
051450	Ladder Safety Cage 150	0	0	1	1	2	2	3	3	4	4	5	5
104132	Ladder Safety Cage 75	1	1	1	0	2	1	2	1	2	1	2	1
051460	Ladder Base	1	1	1	1	1	1	1	1	1	1	1	1
103718	Ladder Hook	2	2	2	2	2	2	2	2	2	2	2	2
103369	Ladder Connector RAPID	2	2	2	2	3	3	4	4	5	5	6	6

A3 Shuttering

Placing of Formwork



Always install the element unit with the concreting platform first. Locating boards facilitate formwork adjustment.

Formwork half with concreting platform (placing formwork)

1. Attach 3-sling lifting gear to the crane eyes, lift formwork to a vertical position and then transport to the place of use. (Fig. A3.01)

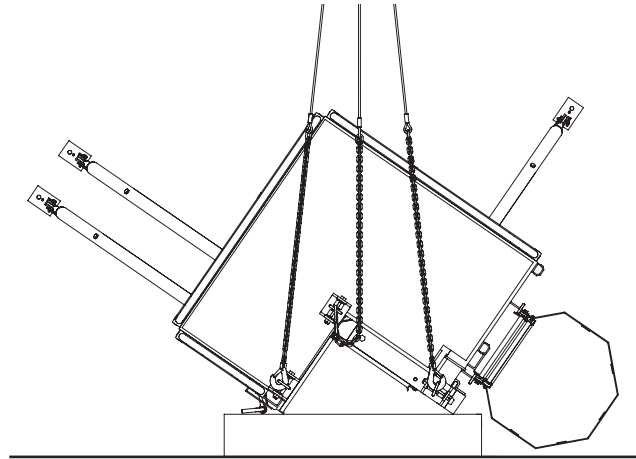

Fig. A3.01

2. Position formwork halves against locating boards. (Fig. A3.02)

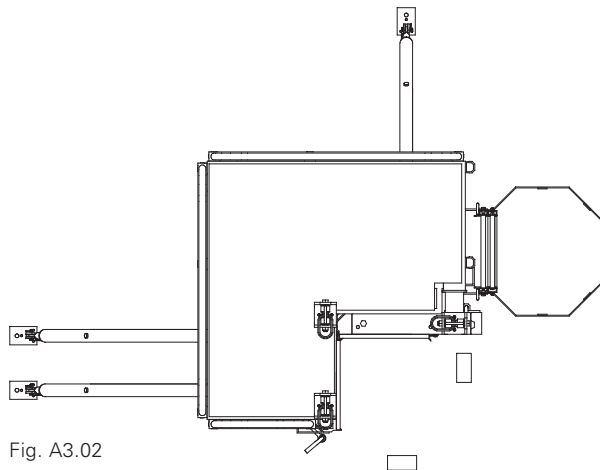

Fig. A3.02

3. Fix base plates of push-pull props and kicker braces to load-bearing foundations/slabs, e.g. with PERI Anchor Bolt.

(Fig. A3.03)

4. Check stability and align.

5. Detach lifting gear.

The first formwork half is now in position.

(Fig. A3.04)

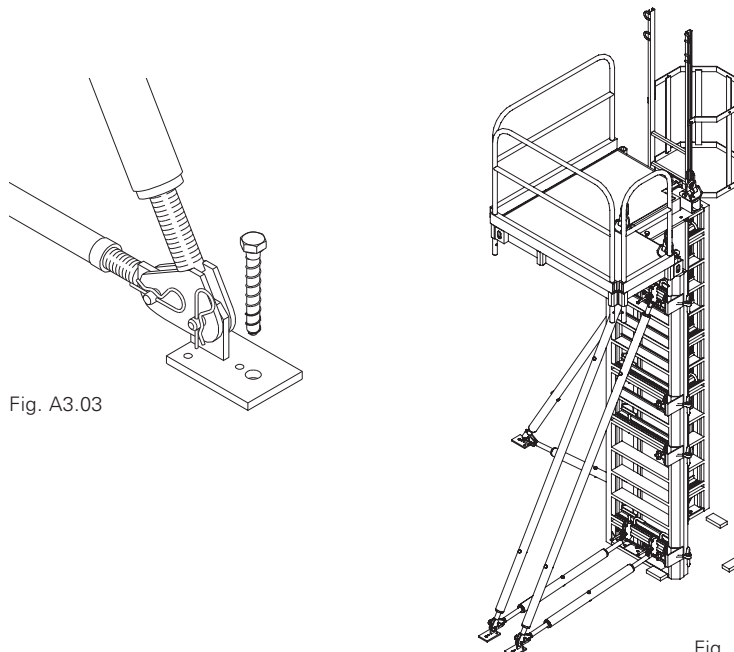

Fig. A3.03

Fig. A3.04

A3 Shuttering

Installation of Reinforcement

Formwork halves with crane eyes (closing formwork)

1. Attach 3-sling lifting gear to the crane eyes, lift formwork to a vertical position and then transport to the place of use. (Fig. A3.05)

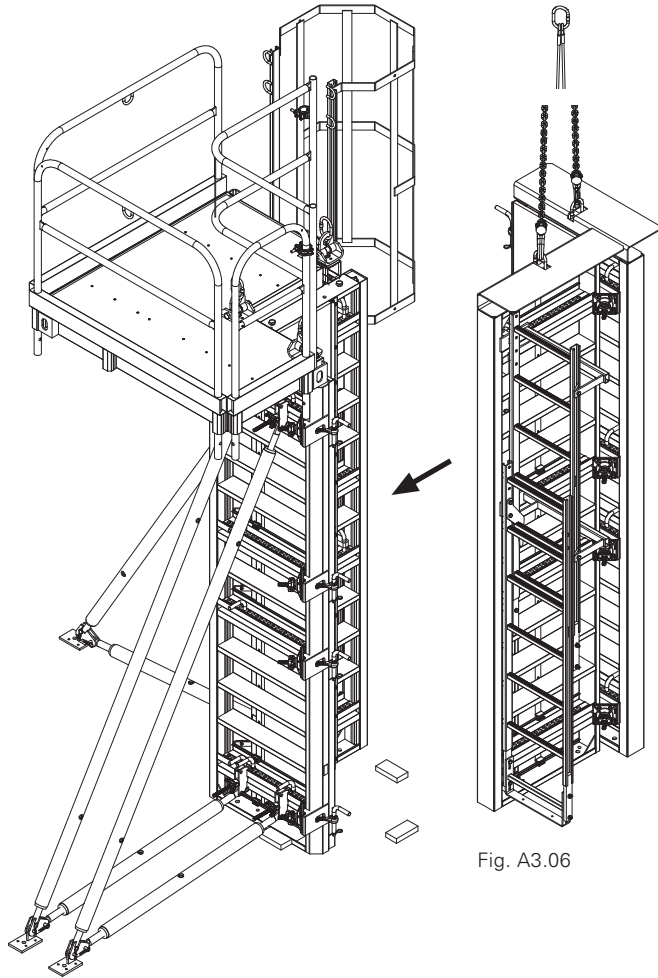

Fig. A3.05

Fig. A3.06

Closing of Formwork



For higher columns, two access ladders are used! Tight formwork from bottom to top.

1. Insert tie yoke through the corner connection. (Fig. A3.07)
2. Insert bolts in the perforated strip. (Fig. A3.07)
3. Tighten with nuts. (Fig. A3.07)
4. Detach lifting gear. (Fig. A3.08)

The formwork is completed.

If needed the Front Guardrail Landing 86/86 (15) can be mounted.

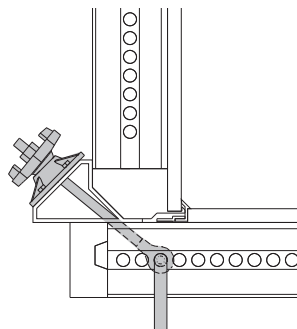

Fig. A3.07

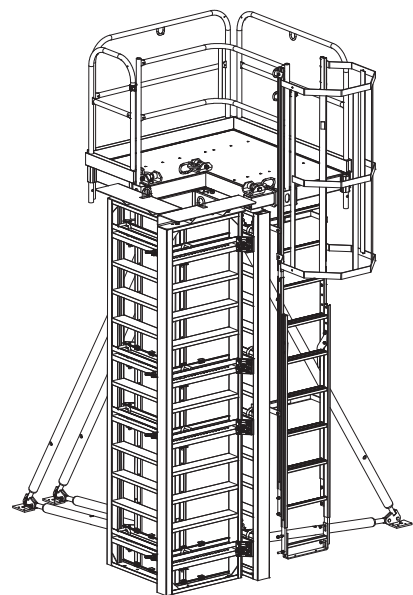

Fig. A3.08

A4 Striking, Moving

Striking and Moving



Push-pull props, concreting platform and ladder access remain attached. Open formwork from top to bottom. The corner connections remain on the column frame (no individual components).

Formwork half without push-pull props

1. Attach lifting gear to the non-supported formwork half and tension.
2. Divide up corner connections between the formwork halves: pull bolts and remove tie yoke. (Fig. A4.01)



Use second ladder access.

3. Place formwork half in position for cleaning.

Formwork half with push-pull props

1. Attach lifting gear to the crane eyes of the concreting platform.
2. Remove base plates of the push-pull props and kicker braces from the ground.
3. Place formwork half in position for cleaning and secure. (Fig. A4.01)

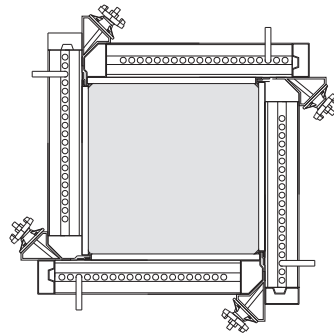

Shuttered.

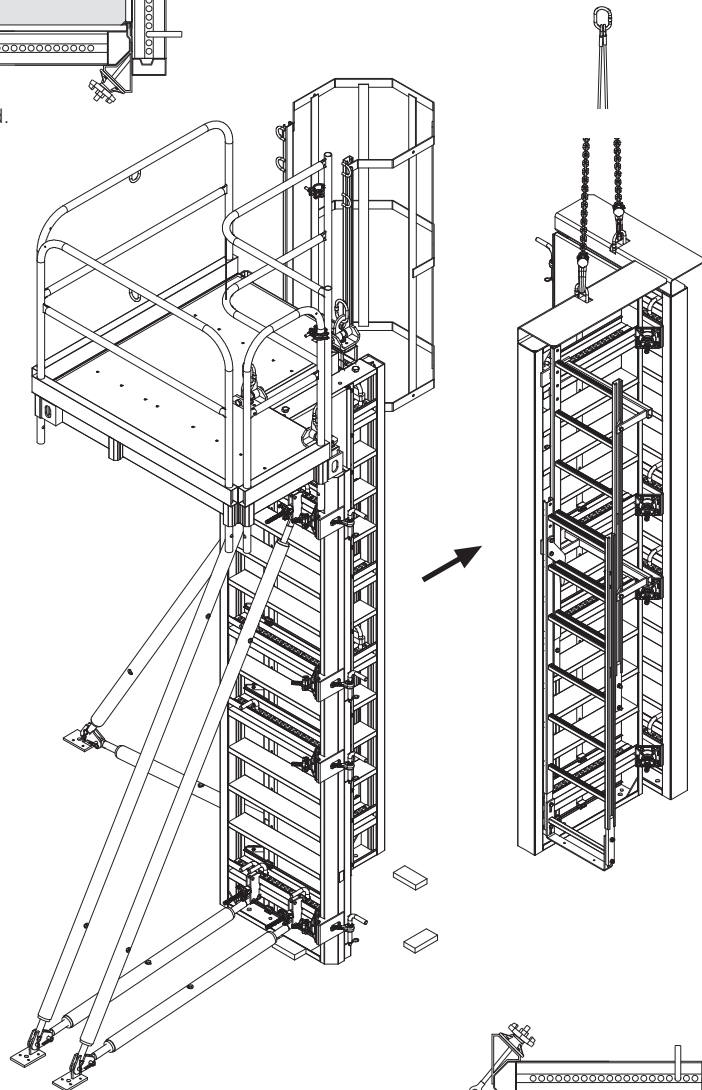
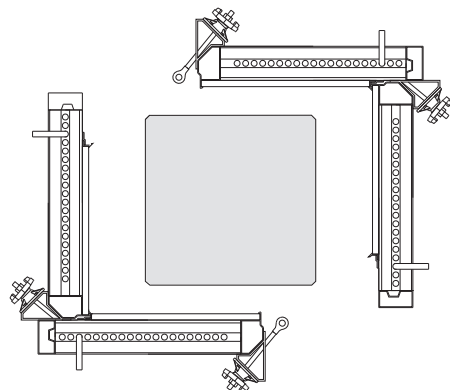

Fig. A4.01



Struck.

A5 Oversized Column Cross-Sections

Oversized Column Cross-Sections

Cross-sections from 85 x 85 cm up to 130 x 130 cm are possible.

For oversized cross-sections, a maximum of two column frames are connected to each other in both length and width.

Connections are made using PERI Alignment Couplers BFD.

1. For bracing, attach waler to each perforated profile with tie yokes and bolts.
2. Install tie in a central position at the height of the waler. (Fig. A5.01)

Table of required Alignment Couplers BFD and Steel Waler SRZ

Height	Alignment Coupler BFD	Steel Waler SRZ 120 U100
Column Frame 300	5	4
Column Frame 210	4	3
Column Frame 60	1	1

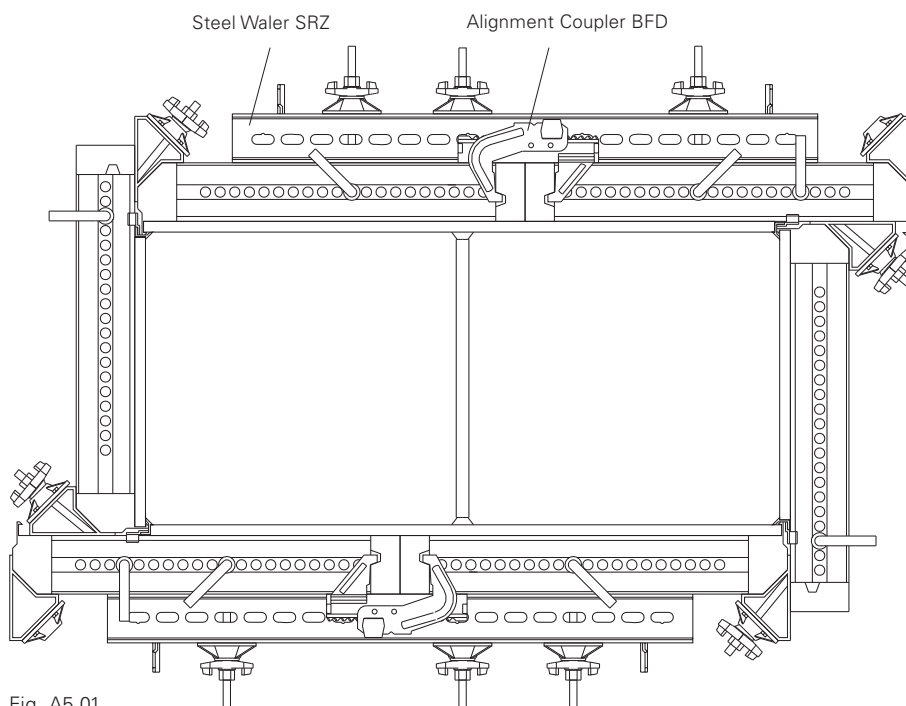

Fig. A5.01

A6 Height Adjustment

Height Adjustment up to 8.10 m

Height adjustments in 30 cm increments are possible with three frame heights.

The column frames are connected using Bolts M20 x 50, SW 30, in the topmost column struts.

Height of formwork [m]	Required number of column frames		
	300	210	60
2.10	-	1	-
2.70	-	1	1
3.00	1	-	-
3.30	-	1	2
3.60	1	-	1
3.90	-	1	3
4.20	-	2	-
4.50	-	1	4
4.80	-	2	1
5.10	1	1	-
5.40	-	2	2
5.70	1	1	1
6.00	2	-	-
6.30	1	1	2
6.60	2	-	1
6.90	1	1	3
7.20	2	-	2
7.50	1	1	4
7.80	2	-	3
8.10	2	1	-

Item no.	Weight kg
037250	61,400

Column Frame RAPID 300 Alu

Column frames for continuously adjustable cross-sections up to 60 x 60 cm. 21 mm plywood forming thickness. With clamping profile for fixing the plywood without screws or nails.

Complete with

- 4 x 037160 Bolt Ø 20 x 205, galv.
- 4 x 037150 Tie Yoke DW 15
- 4 x 030440 Spherical Nut DW 15, galv.
- 2 x 780357 Bolt ISO 4017 M20 x 50-8.8, galv.
- 2 x 710334 Nut ISO 4032 M20-8, galv.

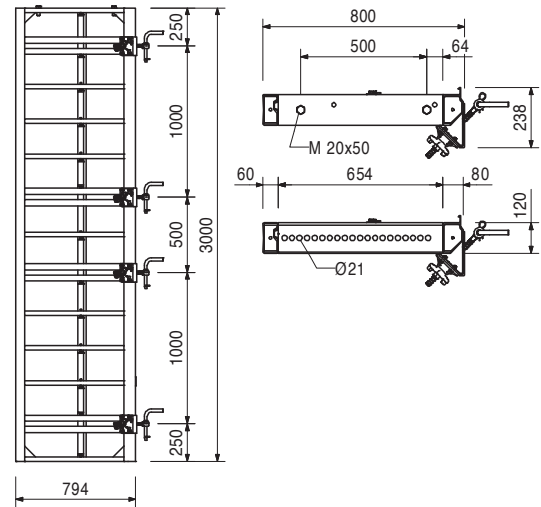
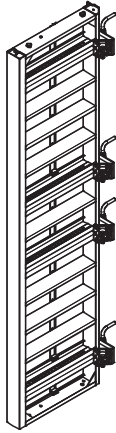

037260	44,800
--------	--------

Column Frame RAPID 210 Alu

Column frames for continuously adjustable cross-sections up to 60 x 60 cm. 21 mm plywood forming thickness. With clamping profile for fixing the plywood without screws or nails.

Complete with

- 3 x 037160 Bolt Ø 20 x 205, galv.
- 3 x 037150 Tie Yoke DW 15
- 3 x 030440 Spherical Nut DW 15, galv.
- 2 x 780357 Bolt ISO 4017 M20 x 50-8.8, galv.
- 2 x 710334 Nut ISO 4032 M20-8, galv.

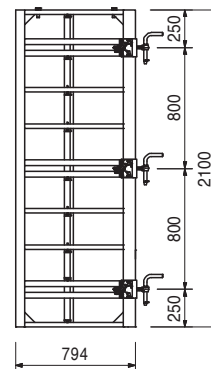
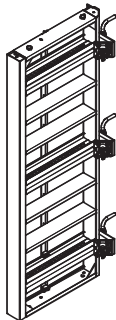

037270	16,700
--------	--------

Column Frame RAPID 60 Alu

Column frames for continuously adjustable cross-sections up to 60 x 60 cm. 21 mm plywood forming thickness. With clamping profile for fixing the plywood without screws or nails.

Complete with

- 1 x 037160 Bolt Ø 20 x 205, galv.
- 1 x 037150 Tie Yoke DW 15
- 1 x 030440 Spherical Nut DW 15, galv.
- 2 x 780357 Bolt ISO 4017 M20 x 50-8.8, galv.
- 2 x 710334 Nut ISO 4032 M20-8, galv.

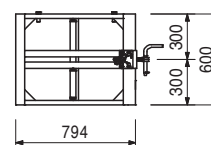
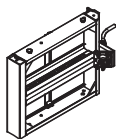

Item no.	Weight kg
037150	0,641

Tie Yoke DW 15

For corner bracing of RAPID column frames.



Technical Data

Permissible load 90 kN.

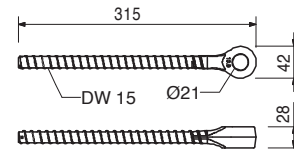

037160	0,736
--------	-------

Bolt Ø 20 x 205, galv.

For corner bracing of RAPID column frames.

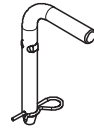

Complete with

1 x 018060 Cotter Pin 4/1, galv.

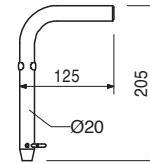

030440	0,686
--------	-------

Spherical Nut DW 15, galv.

For corner bracing of RAPID with DW 15.



Note

Spanner size SW 27.

Technical Data

Permissible load 90 kN according DIN 18216.

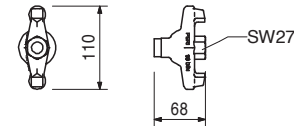

037210	0,320
--------	-------

Chamfer Strip RAPID I = 3.00 m

For installing the plywood formlining on the RAPID column frame.

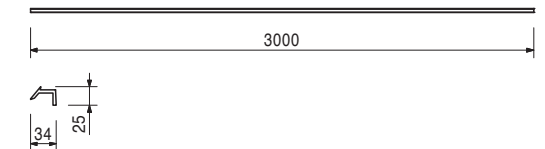
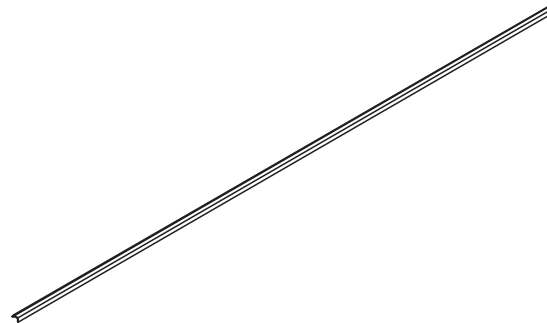

037190	3,010
--------	-------

Brace Connector-3 RAPID, galv.

For connecting push-pull props and kicker braces to the RAPID column frame.

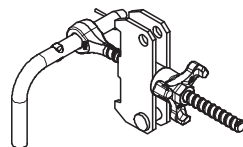

Complete with

1 x 037160 Bolt Ø 20 x 205, galv.

1 x 027170 Bolt Ø 16 x 42, galv.

2 x 018060 Cotter Pin 4/1, galv.

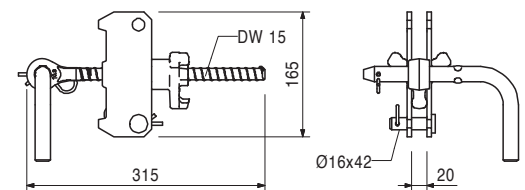

RAPID Column Formwork



Item no.	Weight kg
037320	16,200

Crane Lifting Unit-2 RAPID
For moving RAPID column formwork.

Safety Instructions
Load bearing point capacity 0.5 t.

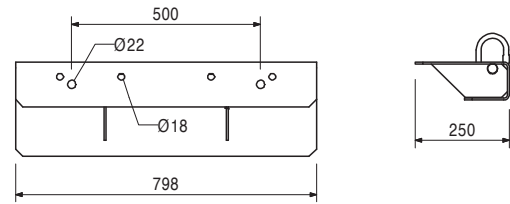
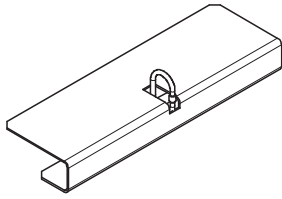

037400	123,000
--------	---------

Concreting Platform, complete
Working and concreting platform for TRIO, RAPID and QUATTRO column formwork.

Complete with
1 x 037410 Concreting Landing, Alu
2 x 037420 Guardrail Landing 52, galv.
2 x 037430 Guardrail Landing 134, galv.
3 x 037440 Crane Hook Concreting Platform

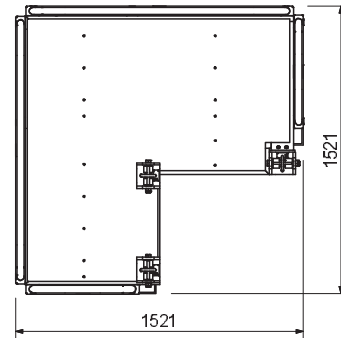
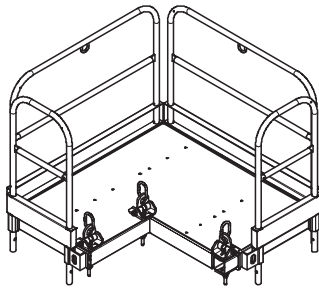

037410	51,400
--------	--------

Concreting Landing, Alu
Continuously adjustable for all column cross-sections up to max. 60 x 60 cm. Attachment is carried out using the crane eye of the concreting platform.

Technical Data
Permissible load capacity 150 kg/m².

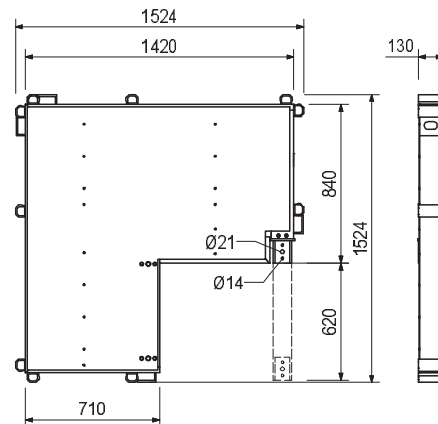
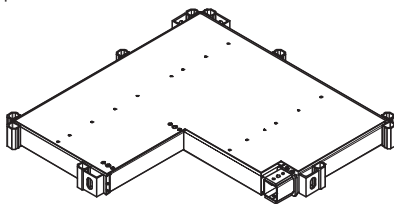

Item no.	Weight kg
037420	10,200

Guardrail Landing 52, galv.

As guardrails for PERI concreting platforms. Locks in place automatically.

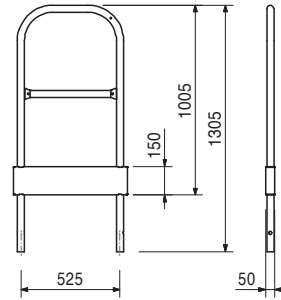
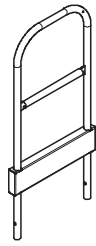

037430	17,100
--------	--------

Guardrail Landing 134, galv.

As guardrails for PERI concreting platforms. Locks in place automatically.

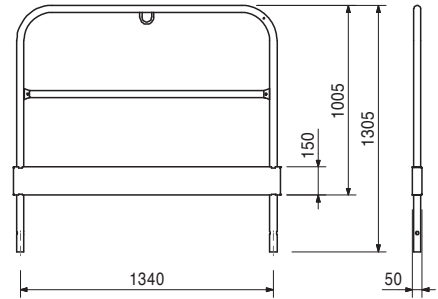
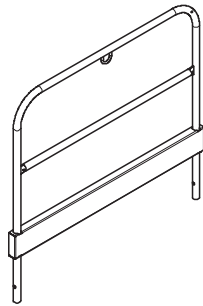

115352	15,100
--------	--------

Front Guardrail Landing 86/86

As guardrails for PERI concreting platforms on the column side. Assembly with screw-on couplings.

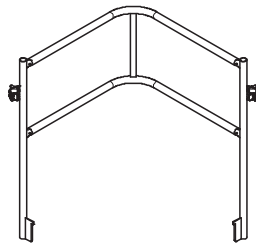

Note

Spanner size SW 19.

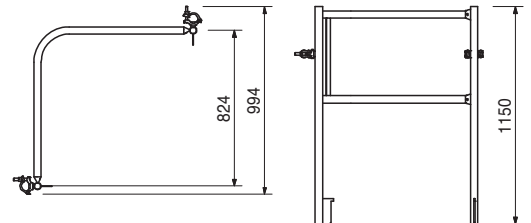

037440	5,660
--------	-------

Crane Hook Concreting Platform

For mounting the concreting landing to TRIO, RAPID and QUATTRO column frames.

Safety Instructions

Load-bearing point load capacity 1.0 t.

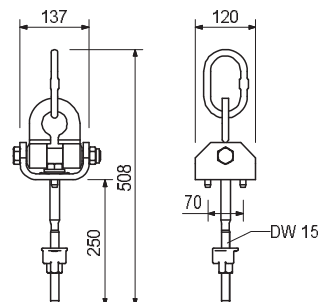
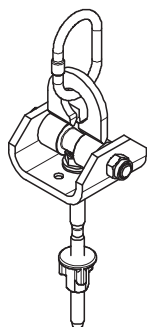

Item no.	Weight kg
051410	11,700

Ladder 180/6, galv.
For accessing PERI formwork systems.

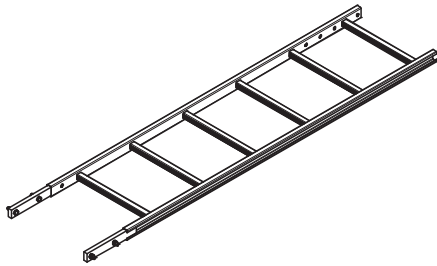

Complete with
4 x 710224 Bolt ISO 4017 M12 x 40-8.8, galv.
4 x 710381 Nut ISO 7042 M12-8, galv.

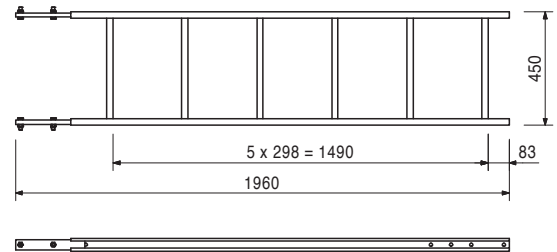

103724	10,400
--------	--------

End Ladder 180/2, galv.
For accessing PERI formwork systems.

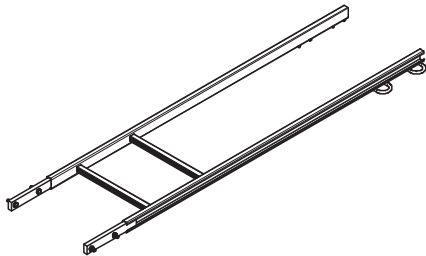

Complete with
4 x 710224 Bolt ISO 4017 M12 x 40-8.8, galv.
4 x 710381 Nut ISO 7042 M12-8, verz.

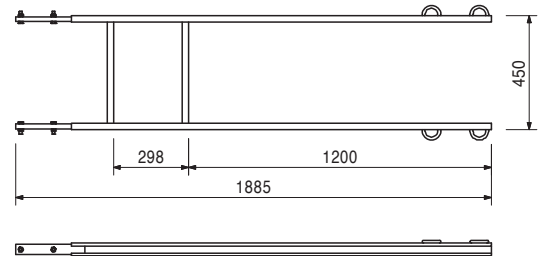

051460	2,180
--------	-------

Ladder Base, galv.
As bottom ladder connection and for securing ladders against sliding on the platform decks.

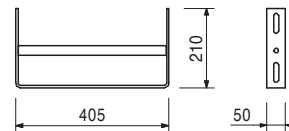
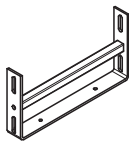

103718	0,684
--------	-------

Ladder Hook, galv.
For adjusting the bottom ladder. Always use in pairs.



Complete with
2 x 710266 Bolt ISO 4017 M12 x 25-8.8, galv.
2 x 710381 Nut ISO 7042 M12-8, galv.

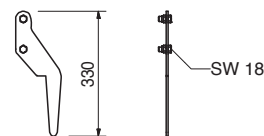

Item no.	Weight kg
103369	6,400

Ladder Connector RAPID, galv.
For connecting ladders to RAPID column frames.

Complete with
2 x 710266 Bolt ISO 4017 M12 x 25-8.8, galv.
2 x 701763 Clamping Plate FI 25 x 10 x 90

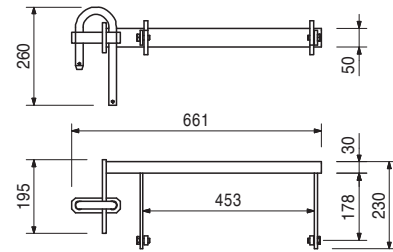
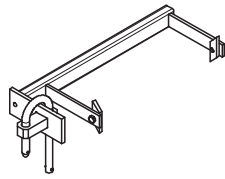

104132	15,600
051450	25,200

Ladder Safety Cages
Ladder Safety Cage 75, galv.
Ladder Safety Cage 150, galv.
Ladder safety cage for PERI access ladders.

Complete with
4 x 710266 Bolt ISO 4017 M12 x 25-8.8, galv.
4 x 701763 Clamping Plate FI 25 x 10 x 90

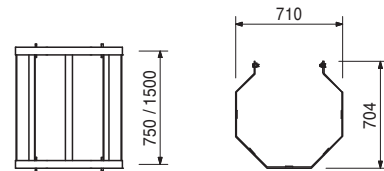
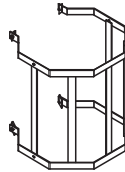

028010	17,800
--------	--------

Push-Pull Prop RSS I
Extension length L = 2.05 - 2.94 m.
For aligning PERI formwork systems.

Note
Permissible load: see PERI Design Tables.

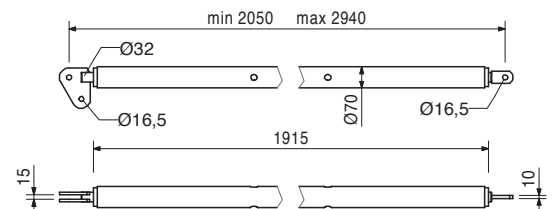
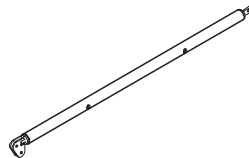

028020	21,900
--------	--------

Push-Pull Prop RSS II
Extension length L = 2.91 - 3.80 m.
For aligning PERI formwork systems.

Note
Permissible load: see PERI Design Tables.

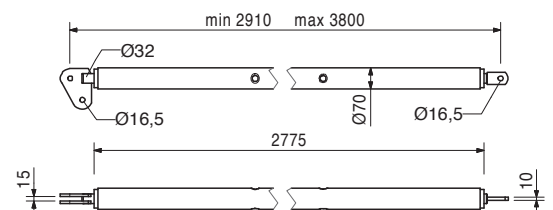
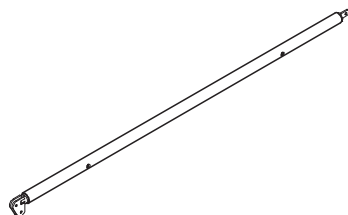

Item no.	Weight kg
028030	38,400

Push-Pull Prop RSS III

Extension length L = 4.60 - 6.00 m.
For aligning PERI formwork systems.

Note

Permissible load: see PERI Design Tables.

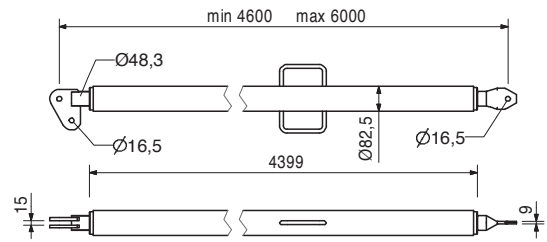
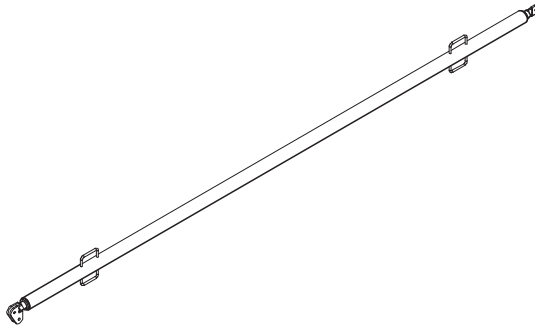

028110	5,180
--------	-------

Kicker AV

Extension length L = 1.08 - 1.40 m.
For aligning PERI formwork systems.

Complete with

1 x 027170 Bolt Ø 16 x 42, galv.
1 x 018060 Cotter Pin 4/1, galv.

Note

Permissible load: see PERI Design Tables.

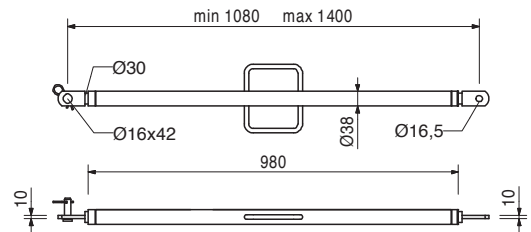
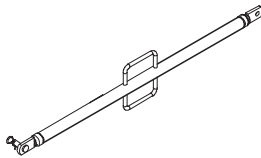

108135	13,000
--------	--------

Kicker AV 210

Extension length L = 1.28 - 2.10 m.
For aligning PERI formwork systems.

Complete with

1 x 027170 Bolt Ø 16 x 42, galv.
1 x 018060 Cotter Pin 4/1, galv.

Note

Permissible load: see PERI Design Tables.

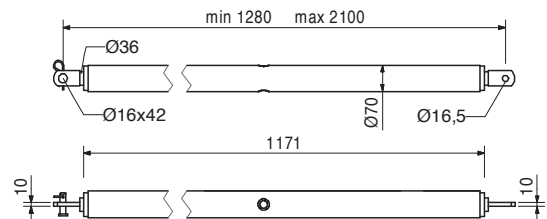
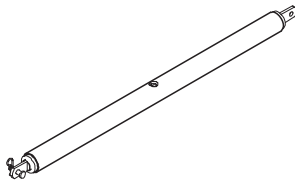

028120	16,900
--------	--------

Kicker AV RSS III

Extension length L = 2.03 - 2.92 m.
For aligning PERI formwork systems.

Complete with

1 x 027170 Bolt Ø 16 x 42, galv.
1 x 018060 Cotter Pin 4/1, galv.

Note

Permissible load: see PERI Design Tables.

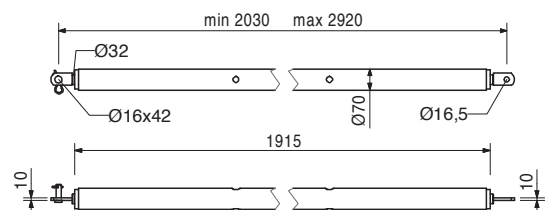
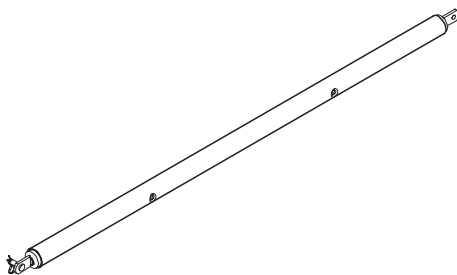

Item no.	Weight kg
106000	1,820

Base Plate-2 for RSS, galv.
For assembling RSS push-pull props.

Complete with
1 x 027170 Bolt \varnothing 16 x 42, galv.
1 x 018060 Cotter Pin 4/1, galv.

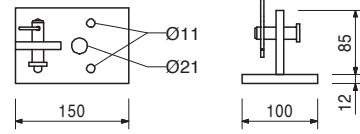
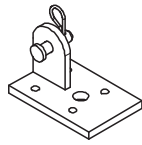



01 PERI GmbH
 Rudolf-Diesel-Strasse
 89264 Weissenhorn
 info@peri.com
 www.peri.com



02 France
 PERI S.A.S.
 77109 Meaux Cedex
 peri.sas@peri.fr
 www.peri.fr

03 Switzerland
 PERI AG
 8472 Ohringen
 info@peri.ch
 www.peri.ch

04 Spain
 PERI S.A.
 28110 Algete - Madrid
 info@peri.es
 www.peri.es

05 Belgium/Luxembourg
 N.V. PERI S.A.
 1840 Londerzeel
 info@peri.be
 www.peri.be

06 Netherlands
 PERI B.V.
 5480 AH-Schijndel
 info@peri.nl
 www.peri.nl

07 USA
 PERI Formwork Systems, Inc.
 Elkridge, MD 21075
 info@peri-usa.com
 www.peri-usa.com

08 Indonesia
 PT Beton Perkasa Wijaksana
 Jakarta 10210
 bpw@betonperkasa.com
 www.peri.com

09 Italy
 PERI S.p.A.
 20060 Basiano
 info@peri.it
 www.peri.it

10 Japan
 PERI Japan K.K.
 Tokyo 103-0015
 info@perijapan.jp
 www.perijapan.jp

11 United Kingdom/Ireland
 PERI Ltd.
 Rugby, CV23 0AN
 info@peri.ltd.uk
 www.peri.ltd.uk

12 Turkey
 PERI Kalıp ve İskeleleri
 Esenyurt / İstanbul 34510
 info@peri.com.tr
 www.peri.com.tr

13 Hungary
 PERI Kft.
 1181 Budapest
 info@peri.hu
 www.peri.hu

14 Malaysia
 PERI Formwork Malaysia
 Sdn. Bhd.
 43300 Seri Kembangan,
 Selangor Darul Ehsan
 info@perimalaysia.com
 www.perimalaysia.com

15 Singapore
 PERI ASIA Pte. Ltd
 Singapore 387355
 pha@periasia.com
 www.periasia.com

16 Austria
 PERI Ges.mbh
 3134 Nußdorf ob der Traisen
 office@peri.at
 www.peri.at

17 Czech Republic
 PERI spol. s r.o.
 252 42 Jesenice u Prahy
 info@peri.cz
 www.peri.cz

18 Denmark
 PERI Danmark A/S
 2670 Greve
 peri@peri.dk
 www.peri.dk

19 Finland
 PERI Suomi Ltd. Oy
 05460 Hyvinkää
 info@perisuomi.fi
 www.perisuomi.fi

20 Norway
 PERI Norge AS
 3036 Drammen
 info@peri.no
 www.peri.no

21 Poland
 PERI Polska Sp. z o.o.
 05-860 Płochocin
 info@peri.pl.pl
 www.peri.pl.pl

22 Sweden
 PERIform Sverige AB
 30013 Halmstad
 peri@periform.se
 www.periform.se

23 Korea
 PERI (Korea) Ltd.
 Seoul 135-080
 info@perikorea.com
 www.perikorea.com

24 Portugal
 PERIcofragens Lda
 2790-326 Queijas
 info@peri.pt
 www.peri.pt

25 Argentina
 PERI S.A.
 B1625GPA Escobar – Bs. As.
 info@peri.com.ar
 www.peri.com.ar

26 Brazil
 PERI Formas e
 Escoramentos Ltda.
 Vargem Grande Paulista
 São Paulo
 info@peribrasil.com.br
 www.peribrasil.com.br

27 Chile
 PERI Chile Ltda.
 Colina, Santiago de Chile
 peri.chile@peri.cl
 www.peri.cl

28 Romania
 PERI România SRL
 077015 Balotești
 info@peri.ro
 www.peri.ro

29 Slovenia
 PERI Slovenien
 2000 Maribor
 peri.slo@triera.net
 www.peri.com

30 Slovakia
 PERI spol. s r.o.
 903 01 Senec
 info@peri.sk
 www.peri.sk

31 Australia
 PERI Australia Pty. Ltd.
 Glendenning NSW 2761
 info@periaus.com.au
 www.periaus.com.au

32 Estonia
 PERI AS
 76406 Saku vald
 Harjumaa
 peri@peri.ee
 www.peri.ee

33 Greece
 PERI Hellas Ltd.
 194 00 Koropi
 info@perihellas.gr
 www.perihellas.gr

34 Latvia
 PERI SIA
 2118 Salaspils novads,
 Rigas rajons
 info@peri-latvija.lv
 www.peri-latvija.lv

35 United Arab Emirates
 PERI (L.L.C.)
 Dubai
 perillc@perime.com
 www.perime.com



- 36 Canada**
PERI Formwork Systems, Inc.
Bolton, ON – L7E 1K1
info@peri.ca
www.peri.ca
- 37 Lebanon**
Lebanon Representative Office
Jdeideh
lebanon@peri.de
www.peri.de
- 38 Lithuania**
PERI UAB
02300 Vilnius
info@peri.lt
www.peri.lt
- 39 Morocco**
PERI S.A.
Tanger
peri25@menara.ma
www.peri.com
- 40 Israel**
PERI Formwork
Engineering Ltd
Petach Tikva, 49002
info@peri.co.il
www.peri.co.il
- 41 Bulgaria**
PERI Bulgaria EOOD
1839 Sofia
peri.bulgaria@peri.bg
www.peri.bg
- 42 Iceland**
Armar ehf.
220 Hafnarfjörður
www.armor.is
- 43 Kazakhstan**
TOO PERI Kazakhstan
050014 Almaty
peri@peri.kz
www.peri.kz
- 44 Russian Federation**
OOO PERI
142407, Noginsk District
moscow@peri.ru
www.peri.ru
- 45 South Africa**
Wiehahn Formwork and
Scaffolding (Pty) Ltd.
7600 Stellenbosch
info@wiehahn.co.za
www.wiehahn.co.za
- 46 Ukraine**
TOW PERI Ukraina
07400 Brovary
peri@peri.ua
www.peri.ua
- 47 Egypt**
Egypt Branch Office
11361 Heliopolis / Cairo
info@peri.com.eg
www.peri.com.eg
- 48 Serbia**
PERI Oplate d.o.o.
11272 Dobanovci
office@peri.rs
www.peri.rs
- 49 Mexico**
PERI Cimbras y Andamios,
S.A. de C.V.
Estado de México,
info@peri.com.mx
www.peri.com.mx
- 50 Azerbaijan**
PERI Kalıp ve İskeleleri
Baku
peribaku@peri.com.tr
www.peri.com.tr
- 51 Turkmenistan**
PERI Kalıp ve İskeleleri
Aşgabat
ahmet.kadioglu@peri.com.tr
www.peri.com.tr
- 52 Belorussia**
PERI Belarus
220030 Minsk
info@peri.by
www.peri.com
- 53 Croatia**
PERI oplate i skele d.o.o.
10 250 Donji Stupnik/
Zagreb
info@peri.com.hr
www.peri.com.hr
- 54 Iran**
PERI GmbH
Iran Branch Office
Tehran
info@peri.ir
www.peri.ir
- 55 India**
PERI (India) Pvt Ltd
Mumbai – 400064
info@peri.in
www.peri.in
- 56 Jordan**
PERI GmbH - Jordan
11947 Amman
jordan@peri.com
www.peri.com
- 57 Kuwait**
PERI Kuwait
13011 Kuwait
kuwait@peri.com
www.peri.com
- 58 Saudi Arabia**
PERI Engineering
Division of Jamjoom
Consult Saudi Arabia
21463 Jeddah
info@peri.com.sa
www.peri.com.sa
- 59 Qatar**
PERI Qatar LLC
P.O.Box: 31295 - Doha
info@periqatar.com
www.periqatar.com
- 60 Algeria**
Société PERI S.A.S.
Kouba - Alger
peri.alger@peri.fr
www.peri.fr
- 61 Albania**
PERI Sh.p.k.
Tirane
erti.hasanaj@peri.com.tr
www.peri.com.tr
- 62 Peru**
PERI Peruana SAC
Chorrillos, Lima
contacto@peri.com.pe
www.peri.com.pe
- 63 Panama**
PERI Panama Inc.
0832-00155 Panama City
info@peri.com.pa
www.peri.com.pa
- 64 Angola**
PERIcofragens, Lda.
Luanda
renato.portugal@peri.pt
www.peri.pt
- 65 Nigeria**
Heights Access Nigeria Ltd.
Victoria Island, Lagos
info@heightsaccessng.com
www.heightsaccessng.com
- 66 Oman**
PERI (L.L.C.)
Muscat
perimct@perime.com
www.perime.com

PERI Product Range



Wall Formwork

Panel Formwork
Girder Formwork
Circular Formwork
Facade Formwork
Brace Frame



Climbing Systems

Climbing Scaffold
Self-Climbing System
Climbing Protection Panel
Platform Systems



Column Formwork

Square
Rectangular
Circular



Scaffold, Stairways, Working Platforms

Facade Scaffold
Working Platform
Weather Protection Roof
Stairway Access



Slab Formwork

Panel Formwork
Beam Grid Formwork
Girder Formwork
Slab Table
Beam Formwork



Bridge and Tunnel Formwork

Cantilevered Parapet Carriage
Cantilevered Parapet Platform
Engineer's Construction Kit



Shoring Systems

Steel Slab Props
Aluminium Slab Props
Tower Systems
Heavy-Duty Props



Services

Formwork Assembly
Cleaning / Repairs
Formwork Planning
Software
Statics
Special Constructions

Additional Systems

Safety Systems
Plywood
Formwork Girders
Stopend Systems
Pallets
Transportation Containers



PERI GmbH Formwork Scaffolding Engineering

P.O. Box 1264
89259 Weissenhorn
Germany
Tel. +49 (0)7309.950-0
Fax +49 (0)7309.951-0
info@peri.com
www.peri.com